User Manual

All-in-One Color Ink-jet Printer D511 series



- Thanks for choosing Deli products.
- Sincere thanks to you for using Deli products!
- Please refer to the actual product for its appearance (the appearance between different models may vary).
- Please carefully read the following statement to protect your immediate rights and interests.
- For more help, please log in www.deliprinter.com
- Version: 1.0

Introduction to the functions of each model of the product

Functions Model	Appearance and colors	Print	Scan	Copy	Wired network	Wireless network	USB connection	Deli Printing APP
D511W	Light gray	●	●	●	-	●	●	●

- “●” indicates supported, and '-' indicates not supported.
- Any addition or change (if any) to the product series will not be further noticed.
- Most of the product images in this manual are based on D511W. Different models may have different appearances.

On the recycling of waste machines and consumables

Deli Group Co., Ltd. is a socially responsible enterprise. In order to promote green environmental protection and contribute to sustainable development, the printing equipment and consumables produced by Deli that you purchased can be disposed of free of charge by the Company. The details are as follows:

1. The user can call the national service hotline of Deli Group 400-185-0555 to register and confirm, and then deliver or send these waste to the nearest branch or service center of Deli Group according to the address provided by the service hotline. According to the principle of shared responsibility, the freight and other related expenses incurred in this process shall be borne by the users themselves.
2. Each branch of Deli Group will return the recycled waste to the group service center who will hand the waste over to a nationally recognized recycling unit for professional recycling and treatment in accordance with relevant laws and regulations of the National Environmental Protection Law. The shipping and recycling costs incurred in this process will be borne by Deli Group Co., Ltd.

Provision of spare parts (components) and consumables

After the production of the printer stops, some spare parts (components) and consumables (print head, ink bottle, ink cartridge) will be provided for 5 consecutive years.

Suggestions for product placement

It is recommended to place this product in a relatively ventilated and independent area.

Suggestions for using recycled paper

To save resources and promote green environmental protection, users can also use high-quality recycled paper.

Suggestions for zero energy consumption

This product can only achieve zero energy consumption after the power plug is disconnected.

Table of contents

Introduction to the functions of each model of the product.....	2
On the recycling of waste machines and consumables.....	2
Table of contents.....	3
Important guidance.....	5
Precautions and safety.....	5
About this manual	5
General safety information	5
Installation location.....	6
Electrical safety.....	8
Warranty	8
Print head. Ink bottle. Ink cartridge.....	8
Maintenance.....	9
Radio interference.....	9
Warning.....	9
Name and content of toxic and harmful substances or elements in the equipment.....	11
How to use	12
Printer component.....	12
Control panel.....	13
Load paper in the tray	14
Insert the original.....	14
Connect and use the printer.....	15
Computer networking for the printer.....	15
Print.....	24
Print with "DELI Inkjet Assistant".....	24
Copy and Scan.....	29
Black and white copy of ID card (host).....	29
Copy settings (host).....	29
Scan with "DELI Inkjet Assistant".....	30
Use of Web Services.....	32
What's Web Services?	32
Accessing the Web interface through the network	32
Web main interface	33
Manage ink and print head.....	35
Keep power-on.....	35
Calibrate the print head.....	35
Clean the print head.....	36
Tips for using ink and print head.....	37
Ink handling precautions	37
Troubleshooting	39
Check the status of this product - printer.....	39
Paper jam.....	42
Paper feed problem.....	43

Printing problem	43
Scan problem	46
Resolve the problem of inability to use Web services	46
Restore factory settings	47
Firmware upgrade	47
Encoder strip contamination.....	47
Appendix	48
Material Safety Data Sheet (MSDS).....	48
Product specifications	48
Copy restrictions	49

Important guidance

Precautions and safety

Before operating this device, please carefully read the following instructions and refer to them as needed to ensure the continuous and safe operation of the device.

The design and testing of Deli printers and printing consumables strictly meet safety requirements, including evaluation and certification by safety agencies, and comply with electromagnetic regulations and established environmental standards.

The safety and environmental testing as well as performance of this device have only been verified using materials printed by Deli.

 **Warning:** Unauthorized modifications, including adding new features or connecting external devices, may affect the normal use of the product. For more information, please contact the Deli Service Center.

Special declaration:

- This manual takes the [D511 series](#) as an example for explanation. The functionality of the product you purchased may vary.
- Product information is subject to change without prior notice.
- For more product information, please visit the official website of Deli: www.deliprinter.com
- Please make sure to read the "Product Safety Manual" thoroughly before reading the "User Manual".
- Deli is not liable for any consequence resulted from non-compliance with the instructions in the Product Safety Manual as well as the losses arising from illegal operations.

About this manual

Please read this user manual carefully. Please follow all safety instructions to ensure the normal operation of the equipment. Deli shall not be liable for the consequences of non-compliance with these instructions.

■ Signs used in this user manual

Signs	Description
	This sign is used to remind users that improper use of this product may pose a fatal threat or serious injury.
	This sign indicates that touch is prohibited, and when this sign appears, touch is strictly prohibited.
▲ Caution	This sign indicates that the user should be more cautious in the operation. Improper operations may cause equipment damage or data missing.
▲ Note	This sign represents an explanation and helps users use this device more effectively and conveniently.

General safety information

Deli reserves the right to make changes to the product from time to time.

The plastic packaging bags of this device and its accessories are not toys. Keep such things out of the reach of children to prevent suffocation hazards. If users having a pacemaker notice any abnormalities in the pacemaker when approaching this device, please immediately stay away from the device and seek medical attention.

If it is not possible to operate this device properly as instructed, please follow the relevant contents in the Instructions. Improper operation may cause equipment damage or expand the scope of damage.

Nothing in this manual shall affect the warranty terms of the device, nor shall any additional warranty terms be added.

Failure to follow the safety instructions in this manual may invalidate the product warranty terms.

If this device is used in a country or region other than that where the product was purchased, it may result in its inability to function properly.

Do not remove or damage any warning labels on the surface or inside the device.

The nameplate is located on the back cover of the printer.

Installation location

Please place this device on a stable horizontal table or cabinet. Do not place this device in a movable table, cabinet, or cart, as falling of the device may cause damage to the device or personal injury; especially for places of children activities, please ensure that the device is placed in a safe location.

Do not place this device in a location with frequent personnel traffic, especially narrow passages or similar locations, to avoid accidental collision or falling of the device, which may cause equipment damage or personal injury.

If the device falls, please immediately cut off the power supply and unplug it, and hand it over to an authorized repair station of Deli for inspection and repair by the professional maintenance personnel.

Please properly arrange the power cord and other cables connected to this device to ensure that they do not trip anyone, otherwise it may cause personal injury or equipment falling damage.

Please place this device indoors with an ambient temperature of 10 °C~32 °C, a humidity of 20% -80%, and no condensation.

The normal working environment temperature of this device is 10 °C~32 °C, and the humidity is 30% -70%.

Do not place the device in any of the following environment, as it may cause the device to malfunction or damage, or even cause a fire.

- Direct sunlight, excessive temperature, proximity to open flames or heat sources, sudden temperature changes.
- Near the water source (including condensation water that may be generated by air conditioning, refrigerators, and fans), humid environment;
- Dust, corrosive gases, or environments near chemicals.

Please place the device in a well ventilated indoor environment and ensure that there is enough space around the device (as shown in the figure).

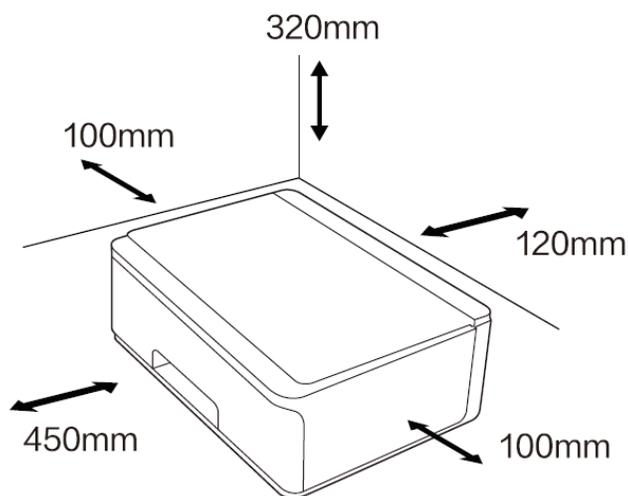

Please ensure that sufficient space is reserved to open the machine cover and feed tray.

Do not place the device in a closed cabinet, as it may overheat or even catch fire.

Do not stack or place any items on this device, and do not insert any items into the gaps of the device casing.

Electrical safety

Please ensure that this device is connected to a grounded AC power source within the rated voltage range as indicated on the label. If unsure, please contact a professional electrician or competent professional maintenance personnel. Use of mismatched AC power sources may cause device damage, fire, or personal injury.

Please use the power connection cable provided with the machine to connect to the wall power outlet and the power interface of this device.

Do not use third-party power cables, as this may cause fire or personal injury.

Please ensure that the power socket on the wall is installed by a professional electrician and well grounded. Do not modify the power cord plug arbitrarily, otherwise it may cause device damage or fire.

The extension cord socket (if any) used shall meet the requirements of the latest national standards.

Before unplugging the power from the AC outlet, please turn off the power switch at the back of the device.

Never not connect this device to the power socket controlled by automatic timer, or do not share the same circuit with high-power appliances such as air conditioner, copier, microwave oven, induction cooking, or it may lead to circuit overload, or even fire.

For plugging and unplugging the power cord, the plug instead of the power cord should be firmly held.

Do not plug or unplug the power cord with wet hands, otherwise it may cause electric shock.

Do not overstretch the power cord, do not step on it, and do not use a damaged power cord, which may cause a fire.

Do not use this device in thunderstorm weather.

If any of the following situations occur, please immediately turn off the device and disconnect the AC power supply, and call the Deli service hotline [63-908-810-9147](tel:63-908-810-9147).

- This device emits odor or abnormal noise
- Worn AC power plug or connection wire
- Tripping of circuit breakers or fuses on the circuit.
- Any component of this device is damaged.
- This device has been invaded by water.

In any of the following cases, please immediately unplug the power and contact Deli maintenance station to have the device handled by Deli professional maintenance personnel.

- This device has liquid leakage.
- This device has been exposed to rain or water ingress.
- This device has abnormal heat, smoke, abnormal noise, and pungent odor.

Warranty

This device does not have any component that users can repair. Do not attempt to disassemble or repair the device on your own, as this may result in hazards such as electric shock. Equipment damage caused by self disassembly or self repair of the device is not covered by the warranty.

Please use genuine print head of Deli. The use of non Deli genuine print head may cause equipment damage that is not covered by the warranty.

If this device malfunctions, please call the Deli service hotline [63-908-810-9147](tel:63-908-810-9147); if necessary, please entrust this equipment to the authorized repair station for professional Deli maintenance personnel to repair.

Print head · Ink bottle · Ink cartridge

Do not disassemble the print head.

The nozzle area of the print head is fragile, so please do not touch it.

During the process of tearing off the protective film of the print head or placing the print head in the carriage, pay attention to protecting the print head and prevent it from falling. Falling may damage the print head.

Keep alert to prevent the ink from entering your eyes or mouth. For eye exposure or ingestion of the ink, please flush with plenty of water and seek medical attention immediately.

Do not shake the ink bottle or ink cartridge violently or subject it to strong impact, which may cause ink leakage.

Place the print head, ink bottle and ink cartridge out of the reach of children.

Maintenance

Please be sure to unplug the power cord before cleaning and maintaining the product.

Please clean the exterior or interior of the device with soft dry cloth or tissue.

Do not use any liquid, spray or detergent of any type to clean the exterior or interior of the device, otherwise fire or electric shock may be caused.

Radio interference

The device complies with the standard GB/T9254.1-2021 Class B.

- Operation frequency: 2.4-2.4835GHz.
- Transmission power: $\leq 20\text{dBm}$ (EIRP).
- Bandwidth occupied: $\leq 40\text{MHz}$ $\leq 2\text{MHz}$.
- Frequency tolerance: $\leq 20\text{ppm}$.
- Stray emission limit: $\leq -30\text{dBm}$.
- Modulation method: BPSK/QPSK/16QAM/64QAM/DBPSK/DQPSK/CCKGFSK $\pi/4$ -DQPSK 8DPSK

Note: In order to operate this device near industrial, scientific, and medical (ISM) equipment, it may be necessary to limit the external radiation of the ISM equipment or take special mitigation measures.

It is not allowed to change the transmission frequency or increase the transmission power (including additional installation of RF power amplifiers) without authorization, and it is not allowed to connect antennas or switch to other transmission antennas without authorization.

Do not cause harmful interference to various legitimate radio communication services during use. Once interference is found, measures should be taken to eliminate the interference before use.

The use of power radio equipment must withstand interference from various radio services or radiation interference from industrial, scientific, and medical application equipment.

Do not use near airplanes and airports.

Warning



This symbol indicates that the product should not be discarded together with other wastes. A more appropriate approach is

to send waste equipment to designated collection points for recycling and reuse of electrical and electronic parts.



This product is suitable for indoor use, not for outdoor use.



It is only suitable for safe use in non-tropical climate conditions.



Only suitable for safe use in areas with an altitude below 2000 m.



Danger: This sign provides a warning of danger to humans, as improper operation may result in personal injury or damage.



This product fully meets the requirements of the Chinese electronic industry standard SJ/T11364-2014.

Special declaration:

Please read this book carefully and follow all safety instructions to ensure the normal operation of the equipment.

Deli shall not be liable for the consequences of non-compliance with these instructions.

Name and content of toxic and harmful substances or elements in the equipment

Component name	Hazardous Substances					
	Pb	Hg	Cd	Cr(VI)	PBB	PBDE
Printer core	○	○	○	○	○	○
Scanning assembly	○	○	○	○	○	○
Plastic case	○	○	○	○	○	○
PCB	✕	○	○	○	○	○
Print head/ink bottle	○	○	○	○	○	○
Power adapter	✕	○	○	○	○	○
Power cord assembly	○	○	○	○	○	○

Remarks:
This table is compiled in accordance with regulations of SJ/T11364.

1. "○" Indicating that the content of the hazardous substance in all homogeneous materials of the component is below the limit requirement specified in GB/T 26572.
2. "✕" Indicating that the content of the hazardous substance in at least one homogeneous material of the component exceeds the limit requirements specified in GB/T 26572.
3. All components with "X" in their names in this table comply with the exemption from the China RoHS List of Exceptions to the Application of Restricted Substances in the Catalogue of Compliance Management.
4. The reference identification for the environmentally friendly usage period depends on the temperature and humidity conditions under which the product operates normally.

How to use

Printer component

D511 series

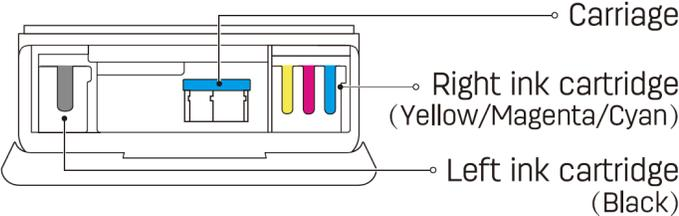
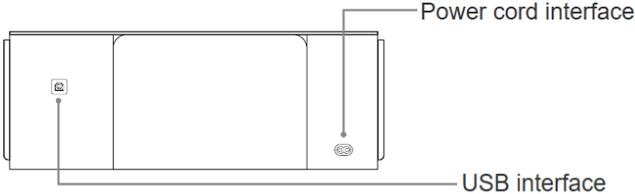
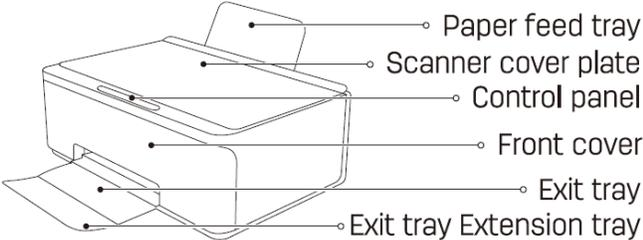

Control panel

Key functions



Return/Cancel	Press once to return to the interface of the upper level . Cancel the current operation. Tips: Open the front cover and press once to move the carriage to the print head installation position.
-/+	Homepage ready status, press once to reduce/increase by 1 copy. Hold for 3 seconds to decrease/increase by 10 copies. Switch menu.
OK/Menu	Confirm the current operation. Enter Menu.
On/Power	Homepage ready status, press once to start copy. Press once to turn on the machine; hold for 3 seconds to shut down .

Load paper in the tray

1. Open the exit tray and extension tray

▲ Note: If the exit tray and extension tray are not opened during use, the paper may easily fall off after printing is completed.

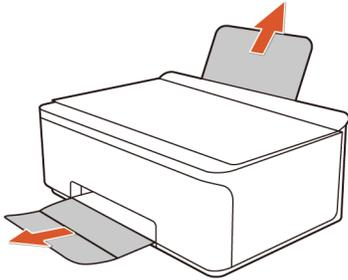

2. Fully spread the stacked paper to avoid paper sticking.

▲ Note: For photo printing, it is recommended to use Deli RC high gloss photo paper or fine velvet photo paper for better printing results.

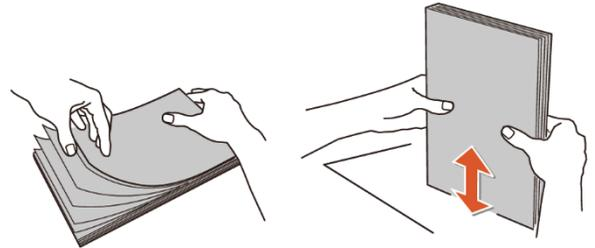

3. Insert paper and adjust the width regulator to clamp the paper.

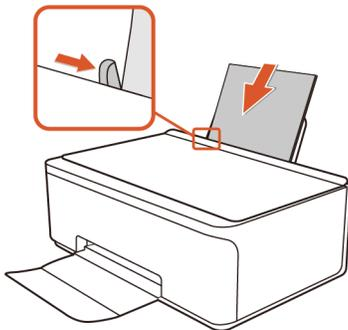

Insert the original

1. Lift the scanner cover plate.

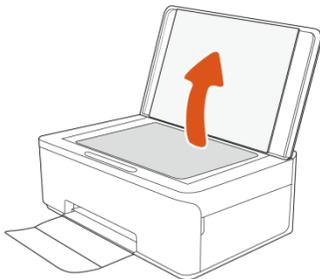

2. Place the original printing face down near the icon in the upper left corner of the presentation platform.

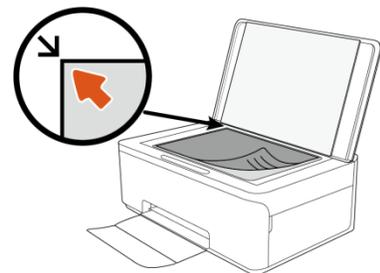

3. Close the scanner cover plate.

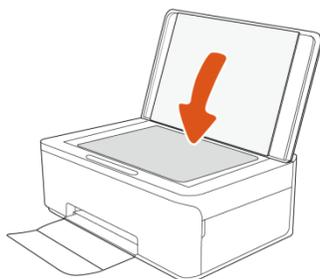

4. Load paper in the feed tray. Place the original printing face down near the icon in the upper left corner of the presentation platform. Press  to make copies.

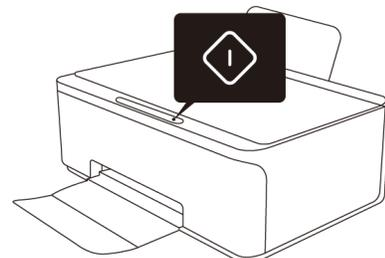

Connect and use the printer

Computer networking for the printer

The recommended computer operating systems are Windows 11 (64 bit), Windows 10 (64/32 bit), Windows 8.1 (64/32 bit), and Windows 7 (64/32 bit).

DELI Inkjet Assistant and driver

▲ Note: "DELI Inkjet Assistant" and the printer driver only support Windows operating system.

Installation

1. Open the browser, enter www.deliprinter.com, search for product models on the official website of Deli, and download "Deli LXXX series inkjet driver version VX.X.X";
2. Find and double-click the "DeliInkJetInstaller_Setup.exe" icon;
3. Click 'Install' to proceed to the next step;
4. After carefully reading the user agreement, click 'Agree';
5. The driver is in the process of installation. When the installation Progress bar is full, click Next;
6. The driver installation is completed.
 - a) The user can choose to immediately "Add printer";
 - b) If it will be added later, choose 'Exit'.

Connect the printer

Connect the printer to the computer with USB cable

The printer supports a USB 2.0 high-speed port on the back to connect to the computer.

If the printer assistant software is installed, the printer can be used as a plug and play device.

If the printer assistant software is not installed, please enter dell123.com in the computer's web browser, download and install the 'DELI Inkjet Assistant'.

▲ Note: Do not connect the USB cable to the printer without a prompt.

1. Follow the instructions on the screen to perform the operation.
2. Connect the USB cable to the printer.

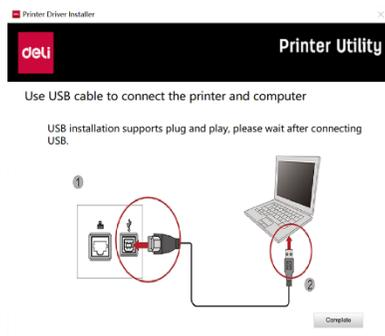

3. If the printer has been connected with USB in advance, View the printer list on the top right of the printer Home screen.
4. Select the connected printer from the drop-down list.

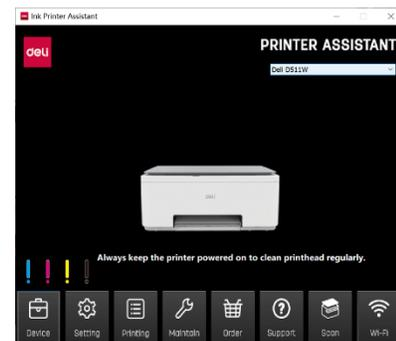
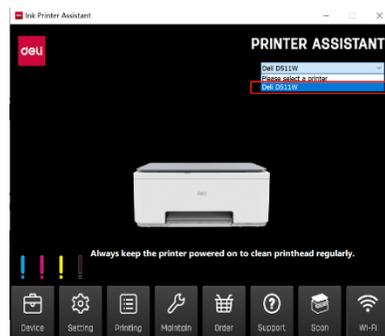

Change USB connection to wireless network connection

If you set up the printer for the first time and have already installed the software with a USB cable, connecting the printer directly to the computer can easily change to a wireless network connection.

A wireless 802.11b/g/n network that includes wireless routers or access points is required.

Before changing from USB connection to wireless network, please ensure that:

- The printer has been connected to the computer through a USB data cable until it prompts to disconnect the USB cable.
- The computer is already connected to the wireless network that the printer needs to connect to.

1. Click "**Wireless Connection**" on the printer assistant Home screen.
2. Please follow the instructions on the screen to operate the wireless network settings interface, and then click '**Next**'.

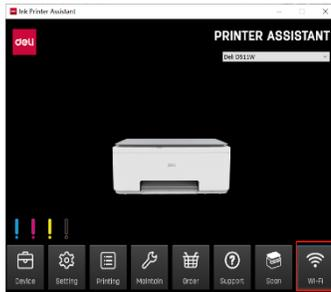

3. Select the target Wi-Fi that is needed to be connected and click 'Next'.
4. If the Wi-Fi is encrypted, please enter the password. **If the Wi-Fi is not encrypted, it enters the connection interface directly.** Then click "Next".

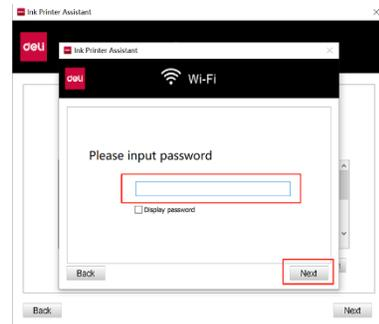
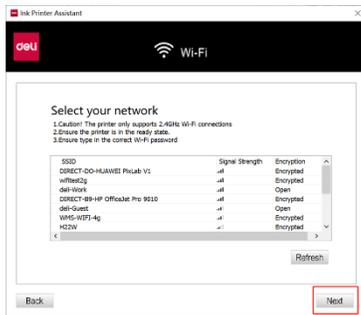

5. Wireless connection succeeded. Then click "Next".

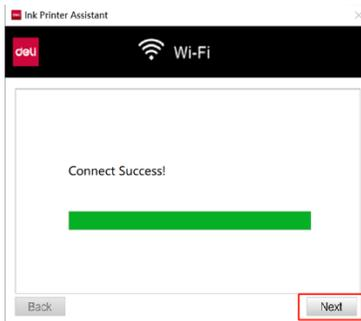

To add a network printer

1. Open the "Deli Inkjet Assistant" and click on 'Device Management'.

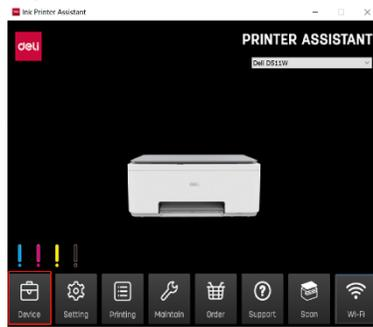

3. The printer assistant will automatically search for printers on the same local area network.

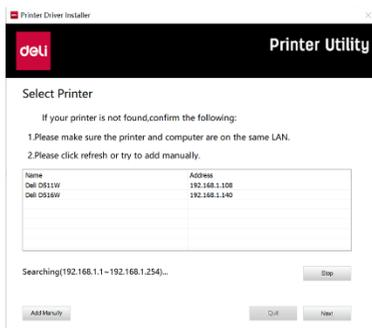

2. Click "Add printer".



4. Select the name of the printer that you want to connect, and then click 'Next' to add the printer successfully.

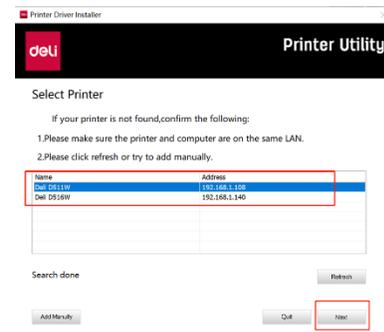

Automatically search and add printers (default search method)

If you want to connect the printer by using "DELI Inkjet Assistant". you need to ensure that the printer and computer are on the same LAN.

- ▲ Note: The printer supports connections with 2.4 GHz.
- Please ensure that the printer is connected to the LAN.
 - Connection method: Please refer to ["Change USB connection to wireless network"](#).
- Ensure that the printer and computer are on the same LAN.

1. Open the "Deli Inkjet Assistant" and click on 'Device Management'.

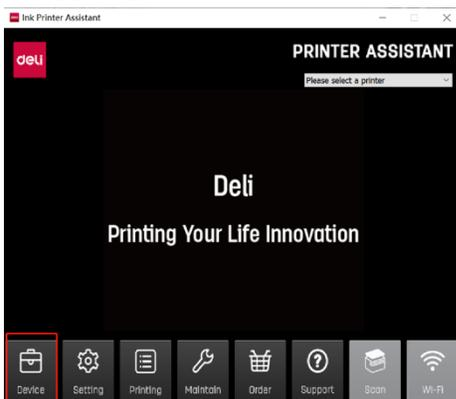

2. Click **Add printer**.

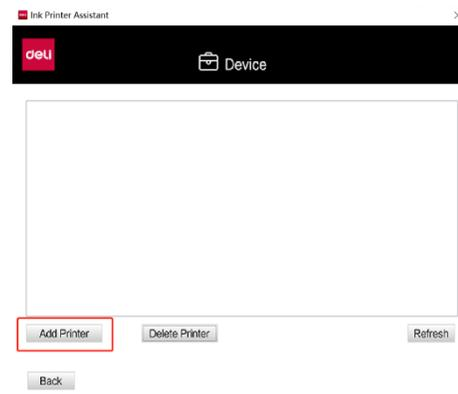

3. Search for printer automatically

The printer assistant will automatically search for printers on the same local area network.

If your printer is not searched:

- Please ensure that the printer is connected to the LAN.
- Ensure that the printer and computer are on the same LAN.
- Alternatively, click Refresh on the current page or try to Add manually.

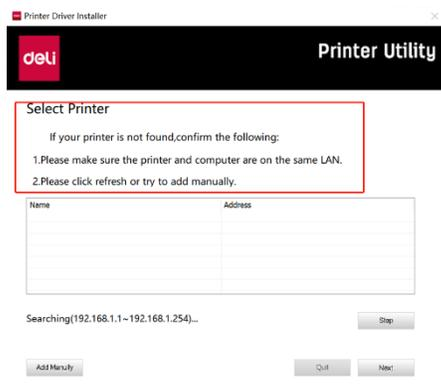

4. Select the name of the printer that you want to connect: Then click **Next**, follow the instructions on the screen to perform the operation.

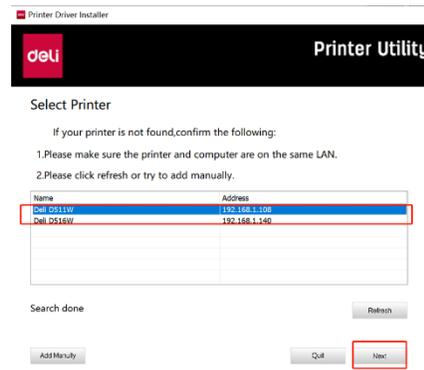

Add printer manually

1. Open the "Deli Inkjet Assistant" and click on 'Device Management'.

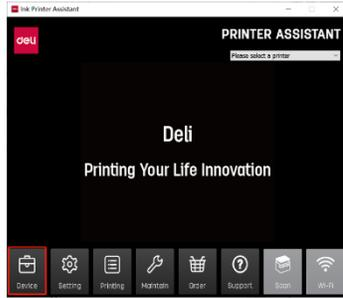

3. Click **Add manually**.

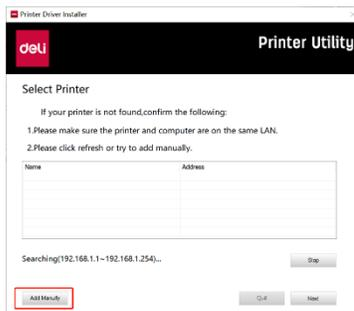

2. Click **Add printer**.



4. Click **Add manually**. Four adding methods appear on the screen

- **Automatically search for network segments.**
This method is the default addition method mentioned above.
- **Set the network segments for searching**
- **Add designated IP**
- **Connect with USB**

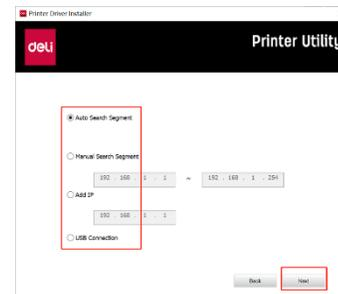

5. Select an appropriate method, then click Next, follow the instructions on the screen to perform the operation.

Item	Description
Automatically search for network segments	The printer driver application automatically searches for printers located on the same local area network as the computer and adds them.
Set the network segments for searching	The printer driver application automatically searches for printers within a certain network segment to adds them.
Add designated IP	Adding a printer by setting an IP address
Add with USB	Connect the printer to the computer with USB

Automatically search for network segments

1. Select **"Automatically search for network segments"** and click **"Next"**
2. Searching (XXX.XXX.XXX.X~ XXX.XXX.XXX.X) ...

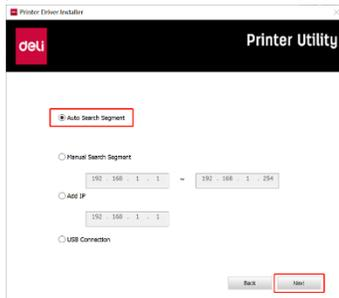

3. Select the printer and click **"Next"**

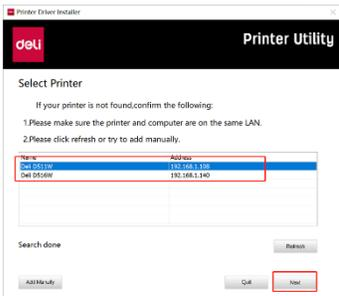

Set the network segments for searching

1. Select **"Set the network segments for searching"** and click **"Next"**
2. Searching (XXX.XXX.XXX.X~ XXX.XXX.XXX.X) automatically...

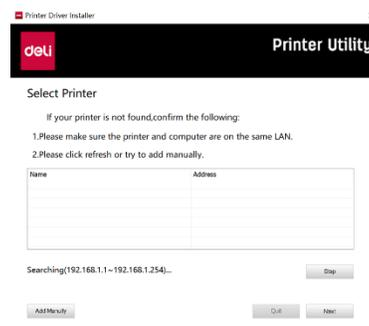
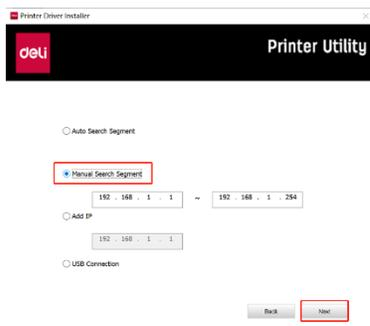

3. Select the printer and click **"Next"**

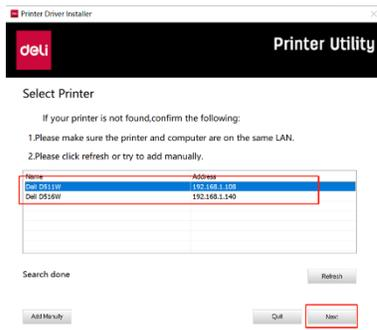

Add designated IP

1. View the IP address of the printer

① Select: Menu -5 Report printing, press OK to print the report page.

- ② View the IP address of the printer.

Wireless network

IP access mode	DHCP
IP address	192.168.1.108
Subnet mask	255.255.255.0
Gateway address	192.168.1.1
Host/ Secondary DNS server	192.168.1.1/0.0.0.0
Network name (SSID)	wifitest2g
Encry mode	WPA/WPA2-PSK
Signal intensity	Strong

3. Adding printer (XXX.XXX.XXX.X)...

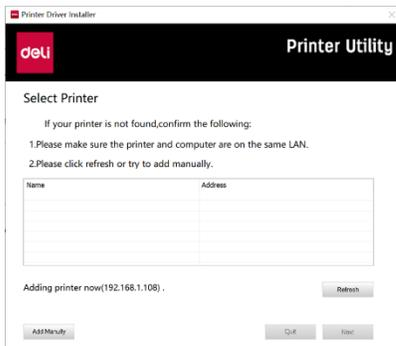

2. Select "Add designated IP" and click "Next"

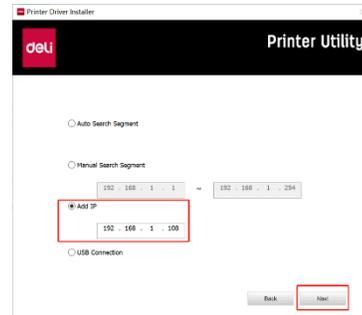

4. Select the printer and click "Next"

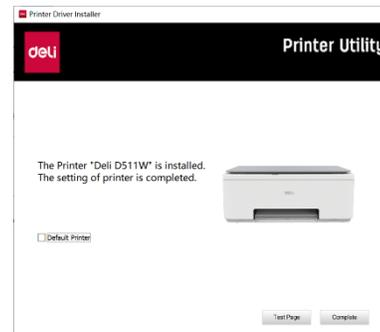

Add with USB

1. Select "Add with USB" and click "Next"

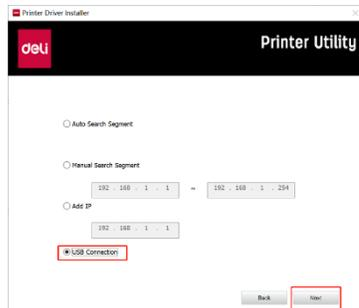

2. Connect the printer and computer with a USB cable and click 'Finish'.

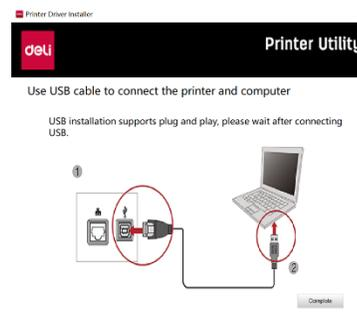

3. Jump to the 'Device Management' interface and check if there is a printer available.

If no such printer, please click 'Refresh'.

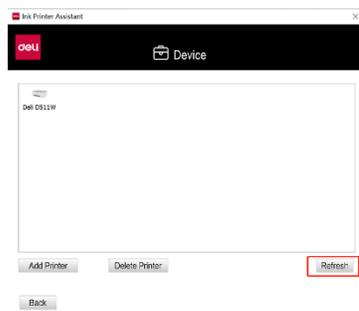

Select/Switch Printers

1. View the printer list on the top right of the printer Home screen.

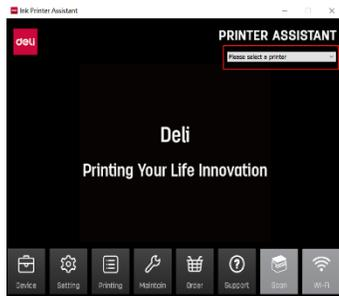

2. Select the connected printer from the drop-down list.

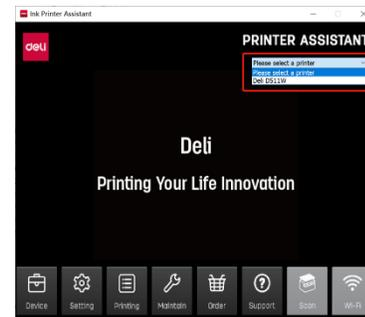

3. When the selection is completed, the connected printer is displayed on the printer Home screen.

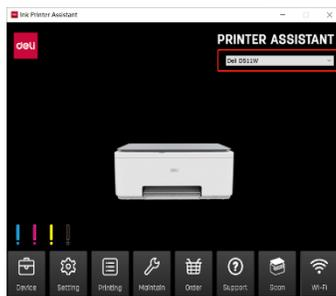

Print

Print with "DELI Inkjet Assistant"

Print document

Before printing the document, ensure that the plain paper is loaded in the feed tray and that the exit tray is open.

Print document (Windows)

1. Select Print from the file menu in the software. **Or press the shortcut key Ctrl+P to print.**
2. Ensure Printer has been selected.
3. Click **the** Properties button to open the dialog box.
Depending on the software application being used, this button may be called Properties, Options, Printer Settings, Printer Properties, Printers, or Preferences.
4. Select the corresponding option.
To change other printing settings, click **Other tab**.
 - On the **Advanced Settings** tab, select the portrait and landscape printing directions.
 - On the **General Settings** tab, select the appropriate paper type (such as plain paper) from the media drop-down list.
 - On the **General Settings** tab, select the appropriate print quality (such as General) in the Print Quality Settings area.
 - On the **General Settings** tab, select the appropriate Paper size (such as A4) from the Paper Size drop-down list.

▲ Note: To change the Paper size, make sure that the correct paper is loaded into the feed tray.
5. Click OK to close the Properties dialog box.
6. Click Print **or** OK to start printing.

Print photos

Before printing the photos, ensure that the photo paper is loaded in the feed tray and that the exit tray is open.

Print photos (Windows)

1. Select Print from the file menu in the software.
2. Ensure Printer has been selected.
3. Click **the** Properties button to open the dialog box.
Depending on the software application being used, this button may be called Properties, Options, Printer Settings, Printer Properties, Printers, or Preferences.
4. Select the corresponding option.
 - On the **Advanced Settings** tab, select the portrait and landscape printing directions.
 - On the **General Settings** tab, select the appropriate paper type (such as photo paper) from the media drop-down list.
 - On the **General Settings** tab, select the appropriate print quality (such as Optimal) in the Print Quality Settings area.
 - On the **General Settings** tab, select the appropriate Paper size (such as 4R/6 inch) from the Paper Size drop-down list.

▲ Note: To change the Paper size, make sure that the correct paper is loaded into the feed tray.
5. Click OK to close the Properties dialog box.
6. Click Print **or** OK to start printing.

▲ Note: After printing, remove unused photo paper from the feed tray. Save photo paper in a timely manner to prevent it from curling to affect print quality.

Print settings (Printing Preferences)

To change the default printing settings, open the "**Deli Inkjet Assistant**", click **Maintenance**, and then click Printer Preferences.

General settings

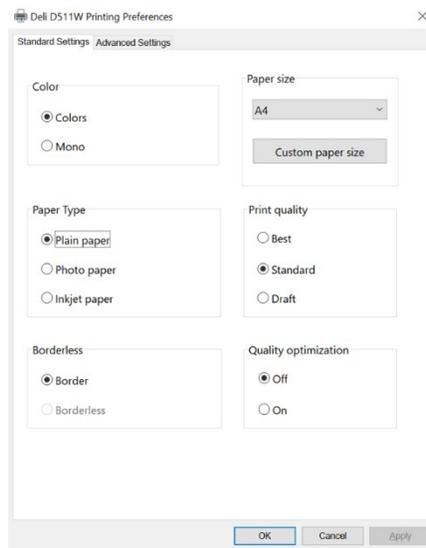

Printing colors: Black/white and color are available for selection.

Color: Use black and color ink for full color printing.

Black and white: Use only black ink for black and white printing.

Paper type: Plain paper, photo paper, or inkjet paper are available for selection.

Borderless: Borderless can only be selected when photo paper is selected as the paper type.

Paper size: A4, A5, envelope DL, envelope C5, special envelope for VAT invoice, B5, 3x5 inch, 4x6 inch, 5x7 inch, Letter, Folio, Legal are available.

Custom paper:

You can set the paper name and size yourself, including name, width, length, and units.

Custom size range: width (W)=[89.0-216.0] mm, length (H)=[127.0-316.0] mm.

Custom units: millimeters, inches.

Print quality:

The print quality is measured according to the print resolution (Dots per inch (DPI)). A higher DPI will generate clearer and finer prints, but it will also reduce printing speed and may use more ink.

Options include Optimal, General, or Draft.

- Draft: The minimum DPI typically used when ink levels are low or high-quality prints are not needed.
- General: Suitable for most printing jobs.
- Optimal: DPI with higher resolution than usual. Suitable for photo printing.

Advanced setting

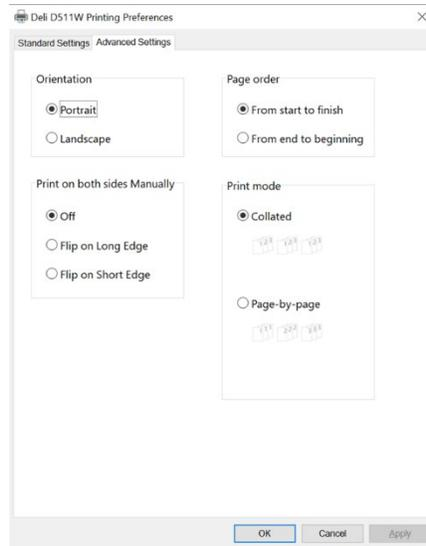

Direction: Used to change the page direction. Portrait and Landscape are available for selection.

Select Portrait for vertical printing; Alternatively, select Landscape for horizontal printing.

Manual duplex printing: After one side of the paper is printed, it is manually flipped to achieve double-sided printing.

The user can choose <Duplex Printing> to use the double-sided printing function. The user can choose None, Flip on Long Edge, and Flip on Short Edge.

Flip on Long Edge: Select this option if you want to flip the paper along its long edge for duplex printing.

Flip on Short Edge: Select this option if you want to flip the paper along its short edge when duplex printing.

Print Page Order: The user can choose to print the document in a page order from front to back or from back to front.

When printing a multi-page document, set the page order from front to back, and the output page order is 1, 2, 3...

Set the page order from back to front, and output the page order as 3, 2, 1...

Paper output sequence:

Collate copies: The document output effect is 1,2,3, 1,2,3, 1,2,3.....;

Page-by-page printing: The document output effect is 1,1,1, 2,2,3, 3,3,3.....

View print job status and manage print jobs

View, pause, or cancel the current print job.

Entry for canceling print jobs

Method 1: On the printer homepage, click **Print List**.



Method 2: Double click the printer icon on the computer Taskbar (lower right corner of the computer desktop) to [call up the Windows system print list](#).



1. View the content being printed, select <Print Task>, right-click, and then click <Cancel>.
2. Then select <Yes> to cancel the print task.

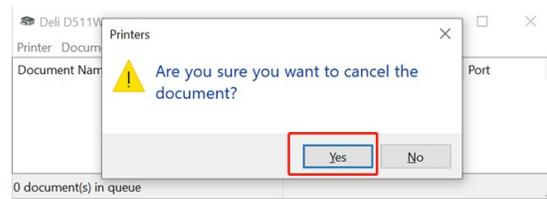

Copy and Scan

Black and white copy of ID card (host)

Select Menu ->2 ID Card Copy, **press OK, and follow the screen prompts to place the ID card**

- ▲ **Note:** When copying, it is necessary to place the ID card horizontally in any position in the A5 landscape area at the top left corner of the scanning panel.

Copy settings (host)

Copy settings: color, quality

- Color: Color, black and white; the default is color, but you can set to black and white
- Quality: Standard, Optimal; the default is Standard, you can set to Optimal

Scan with "DELI Inkjet Assistant"

▲ Note: "DELI Inkjet Assistant" and the printer driver only support Windows operating system.

Before scanning from your computer, please ensure that 'Deli Inkjet Assistant' application driver has been installed.

The printer and computer must be connected and turned on.

If you don't know how to connect the printer to the computer? Please refer to the ["Connections"](#).

Scan documents or photos to a local folder on your computer (Windows)

1. Place the original printing face down near the icon in the upper left corner of the presentation platform. In the 'Deli Inkjet Assistant' (which can be opened from the Start menu), click Scan.

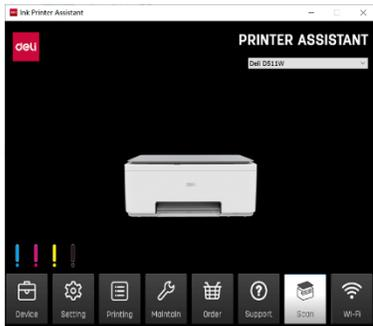

2. View or modify scanning settings.

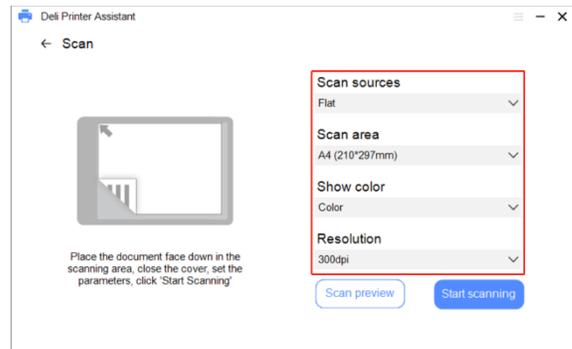

3. Click **Start scanning**

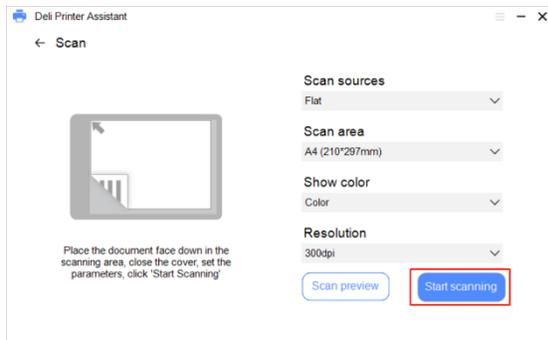

4. After the scanning is completed, the scanned file can be optimized. If there is no need to process, you can click **Save the file or Continue scanning**.

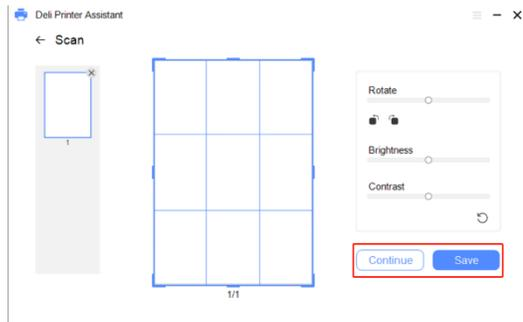

Scan Settings

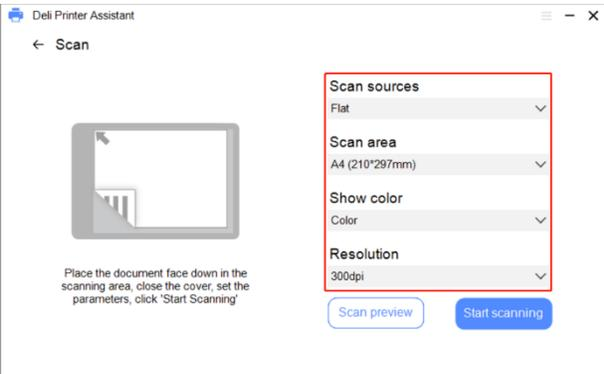
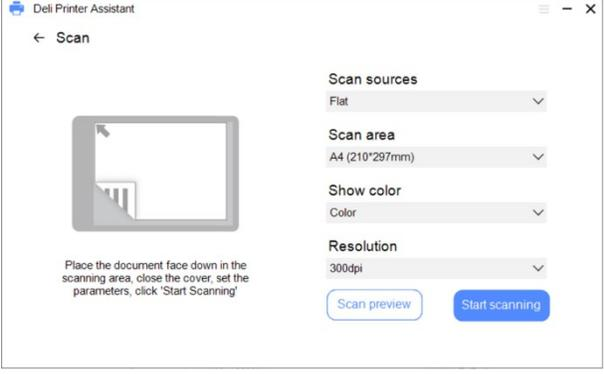
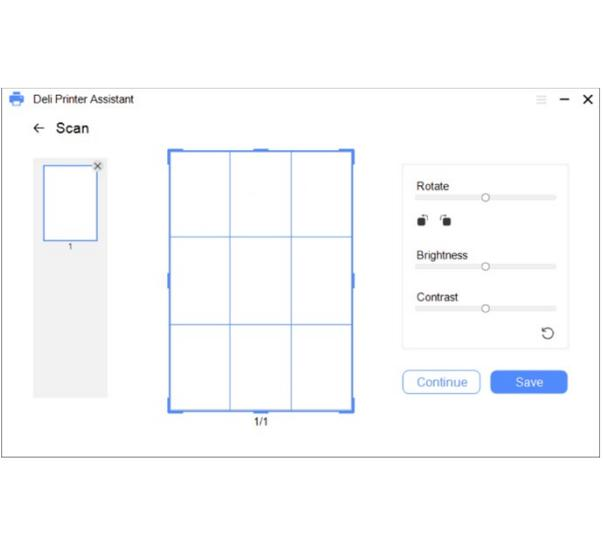
	<p>Basic settings for scan function</p> <ol style="list-style-type: none"> 1. Scan source Available paper source: tablet. 2. Scan area Optional storage types: A4, Entire scanning area, Letter, JIS B5, A5. 3. Show color Optional color formats: color, black and white. 4. Resolution Optional scanning resolution: 300dpi, 600dpi, 1200dpi.
	<p>Scan preview Scan preview: Click preview scan to trigger scan preview.</p>
	<p>Scan optimization</p> <p>After the scanning is completed, it will enter the following interface for optimizing the scanned image.</p> <ol style="list-style-type: none"> 1. Adjust the order: Drag the preview image on the left side up and down. 2. Delete any page: Select the preview image on the left and click the button in the upper right corner of the preview image to delete the current page. 3. Cropping: Drag the blue cropping box, the user can crop the image size according to his own needs. 4. Manual rotation: The user can drag the rotation Progress bar button to adjust the angle of the image according to his own needs. 5. Rotation: Rotate 90° to the left and 90° to the right. 6. Brightness: -100~+100, the user can adjust the brightness of the image according to his own needs. 7. Contrast: -100~+100, the user can adjust the contrast of the image according to his own needs. 8. Reset: The user can reset parameters according to his own needs.

Use of Web Services

What's Web Services?

The Web interface can be used on all operating systems.

The user can access the web interface with the browser on his computer and make various settings for the device.

If the device is connected to the network through a wired or wireless connection, it can access the web interface.

- ▲ Note: Before starting the operation, please ensure that the computer and the device are connected to the same network.

Accessing the Web interface through the network

1. On the printer, operate **Menu ->5. Report printing, Print configuration report.**

- ▲ Note: The printer must be connected to the LAN and have a fixed IP address.

2. In the configuration report, please find: **WEB interface access address and Administrator password.**

D511W Series Configuration Report **deli**

 Equipment information Model D511W Serial number J1771436V015 Firmware version CK_1.00.012_int06	 Connection guidance Bluetooth distribution network 1. Make sure Bluetooth and Wireless network are enabled; 2. Turn on Deli Print-APP; 3. Click "Add Printer" and select a nearby device; 4. Select Wireless network and enter the password. Reset the network: To re-configure the network with the Deli Print-APP, please reset the network first (turn on Bluetooth). The steps are as follows: 1. Press the "OK" key to enter the menu; 2. Press the keys "<" and ">" to switch the menu and find the reset network; 3. Press the "OK" key, and follow the on-screen prompts to confirm the network resetting.
 Equipment statistics Total page count 267 Borderless printing page count 13 Page scanned 64	
 Supplies information Print head calibration status Uncalibrated Ink remaining (C/M/Y/K) Normal CMYK Empty	
 Equipment configuration Language EN WEB interface access address http://192.168.1.108/ Admin password admin	 Driver download Windows Driver download: ru.deliprinter.com

3. In a Web browser supported by your computer, type the IP address or host name assigned to the printer.
For example, if the IP address is 192.168.X.XX, type the following address in the Web browser: http://192.168.X.XX.

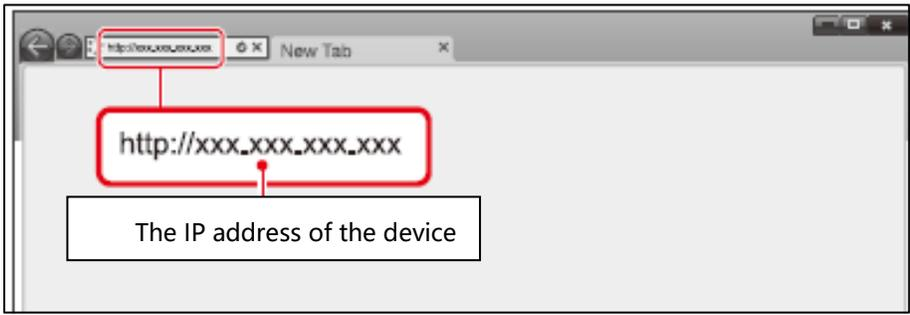

4. When using it for the first time, it needs to set a password to access all the features on the Web interface.

After setting the password, there is no need to set it again.

- 1) To view settings other than **Device Status**, the user needs to log in by entering the password.

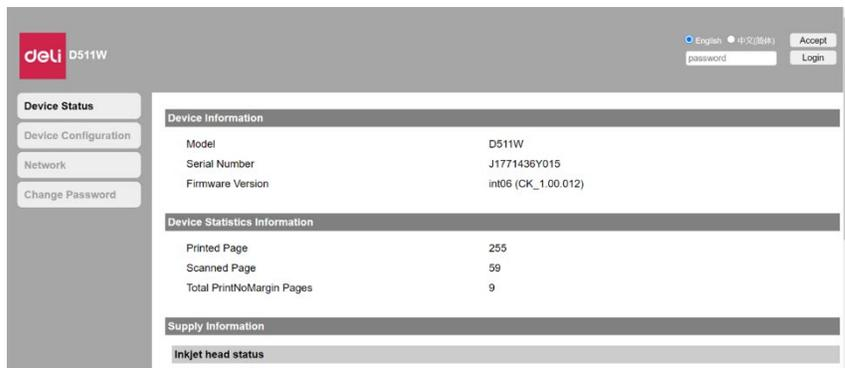

- 2) The default password is 'admin'.
- 3) The password can be changed through the option Menu Tab of the **Login Password**.

Web main interface

The interface logged in after entering the password

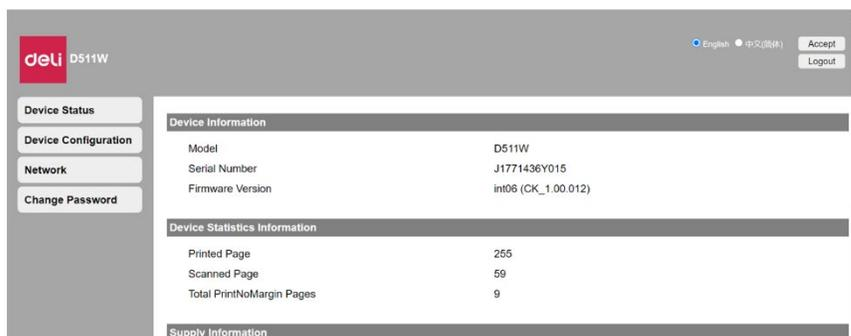

I. Device status

You can check the status of the device, including device information, device statistics, and consumables information.

II. Device configuration

1. General settings: Paper type/Paper size/Paper detection.
2. Energy-saving mode
Sleep waiting time: You can change the time required before the device enters sleep mode: 1 minute - 240 minutes.
3. Print report: The user can print the configuration report.
▲ Note: You can also print the configuration report by using the control panel.
4. Maintenance
Cleaning mode: Clean the print head.
▲ Note: You can also clean the print head by using the printer control panel.
5. Restore factory settings: This device can be restored to the default settings.
▲ Note: After resetting to factory settings, the device will automatically restart. (Due to a disconnected network, the Web interface call will be disconnected.)

III. Network

You can disable or set the status of the network as necessary. If you are not familiar with network management, please use the default settings.

▲ Note

To manually assign IP addresses, please proceed with caution. Incorrect IP address entered will result in impossibility to connect to the device. After configuration changes, if you are unable to connect to the device, please reset the device.

When changing the network connection of the device, the Web interface call will be disconnected. If necessary, please reconnect to the Web interface.

1. Enable Wi-Fi
2. TCP/IP (IPv4) setting: Ethernet/Wireless. You can change settings such as IP address.

▲ Note

The initial value of the IP acquisition is DHCP.

3. IPV6 setting: You can set the host name in this mode, and view its IP address and prefix length.
4. Wireless LAN setting: You can change the connection settings by setting the network name (SSID)/security mode/password format/password for the wireless connection.

▲ Note

If you access this device wirelessly, changing the connected Wi-Fi network in this setting will disconnect Web interface access.

5. Proxy server setting: You can connect to the network through a proxy server.

IV. Login password

You can change the login password for the Web interface.

▲ Note

Write down the password to prevent forgetting it.

If you forget your password, you can execute [Restore factory settings] on the printer operation panel to reset all settings such as password to factory default settings.

After resetting the printer, you can log in with the default password "admin".

The password can only contain half width alphanumeric characters, with a character length range of 1 to 32.

Using the default password 'admin' allows full access to all settings, but there may be unauthorized third-party access. It is recommended that you change the password.

Manage ink and print head

Keep power-on

The print head requires automatic and regular maintenance, and maintenance requires a power supply. Please keep the machine powered on.

- ▲ Note: If the carriage does not return to the right maintenance station, the printer is powered off and the print head will quickly dry out.

Calibrate the print head (initial installation of the print head)

For initial installation, the print head requires mandatory calibration, otherwise it should not proceed to the next process; After the initial calibration fails, it is recommended to print the calibration page again for calibration, otherwise it may affect the print quality.

Calibrate the print head

In any of the following cases for the printed content, please choose to calibrate the print head to improve print quality.

- **Text or image double impression**



- **Uneven lines**

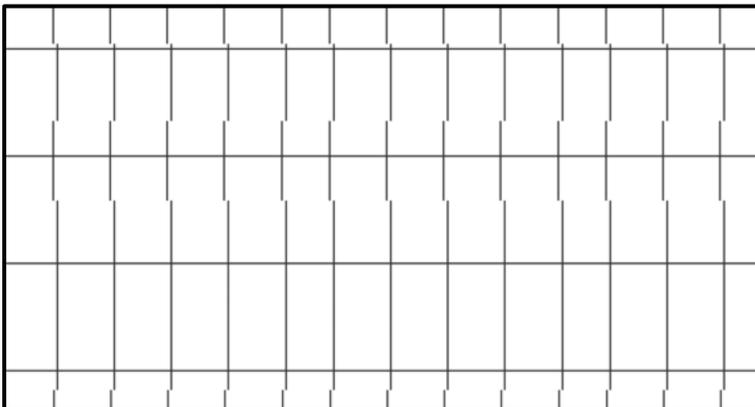

- ▲ Note: Before calibration, please confirm that the printer power is turned on and connected to the computer. Load unused A4 plain paper into the feed tray.

Calibrate the print head (host)

1. Load unused A4 plain paper into the feed tray.
 - a) Select **Menu->3. Calibrate**

-
2. Print calibration page:
 3. **Calibrate the print head:** By referring to the calibration page and following the calibration interface prompt, the user can place the calibration page on the scanning stage and click  to start calibration.

Clean the print head

In any of the following cases, please choose to clean the print head to improve print quality.

- **A certain color missing**



- **Non-uniform text tone**



- **Obvious lines on the image**



- ▲ **Note:** Before cleaning, please confirm that the printer power is turned on and connected to the computer. Load unused A4 plain paper into the paper tray.

Clean the print head (host)

1. Load unused A4 plain paper into the feed tray.
2. Select: Menu ->4 **Clean**, press **OK** to print the clean page.
3. Print the clean page to optimize print quality.

Tips for using ink and print head

Tips for print head

When using the print head, please refer to the following tips:

- Please use genuine Deli print head.
- To prevent the print head from drying out, be sure to use the  Power Button to turn off the printer until the  Power Indicator turns off.
- Do not open the print head or remove the plastic tape from the print head before installing it. Leaving plastic tape on the print head can reduce ink evaporation.
- Please install the black and color print heads correctly.
- After installing the print head or completing printer settings, do not open the carriage buckle, unless necessary.
- After calibrating the print head, excellent print quality can be achieved.
- Regardless of the reason for removing the print head from the printer, it should be reinstalled as soon as possible. If the print head is placed outside the printer without protection, **it may experience blockage, disconnection, or other unpredictable quality issues.**

Tips for ink

When using the ink, please refer to the following tips:

- Before printing, make sure that there is enough ink in the ink bottle.
- Replace the ink bottle or ink cartridge of low ink in time. Printing with insufficient ink may damage the printer.
- Do not tilt the printer.

▲ Note:

The genuine printing head of Deli is designed specifically for Deli printers, which can provide you with high-quality printing results every time you print.

Deli cannot guarantee the quality and reliability of non Deli original consumables. The maintenance or repair of the product caused by the use of non Deli original consumables is not covered by the warranty.

Ink handling precautions

Precautions for ink storage

- Store ink at a standard room temperature of 5° - 35 °C and avoid direct sunlight.
- After removing ink from a cooler storage location, it should be allowed to warm at room temperature for at least 4 hours before use.
- Opened ink should be used as soon as possible.

Precautions for refilling ink

- Use the correct numbered ink bottle or ink cartridge for the product.
- During the use of this product, it is necessary to handle the ink carefully. The ink may splash out during replenishment, and the ink splashed on your clothes or other things may not be easily removed.
- Do not violently shake or squeeze the ink bottle or ink cartridge.
- To achieve better printing results, please keep the ink level sufficient.

Ink consumption

- To maintain good performance of the print head, it not only consumes ink during printing, but it also consumes ink during maintenance (such as cleaning the print head).
- Due to differences in printed images, printing settings, paper types, frequency of machine use, and temperature, the number of pages printed by ink may vary in actual printing.

Troubleshooting

Check the status of this product - printer

Indicator and the status of the product

- The indicator light on the printer operation panel will indicate the status of the product. When an error occurs, the indicator light will stay on or flash.
- When an error occurs in the "Deli Printing APP" on the mobile terminal, detailed information about the error will be displayed. Please follow the detailed solution.
- When an error occurs in the "Deli Inkjet Assistant" on the computer, the detailed information about error will be displayed. Please follow the detailed solution.

Screen display	Situation	Actions
XX ink low	D511 series: Due to the estimated ink level, which differs from the actual ink level, 'XXX ink level is low' will not be displayed.	Ink levels below 15% will not affect normal printing by the user. Please purchase XXX ink that has been low in advance.
	The printer has reached its lifespan (20000 pages).	Please contact the customer service The user can continue printing, but Deli no longer provides warranty services.
Put in paper or place the paper again, and press  to continue printing.	There is paper in the feed tray, but the paper feeding motor fails to feed the paper in.	Remove the paper from the feed tray, then reinsert the paper. After that, press the power button to continue printing jobs. You can also press the return button to cancel the jobs.
Paper jam. After recovering, please press  .	Paper jam at the paper feed tray	First pull out the paper and press the return button to clear the fault code
Please select the matching paper and press  .	Incorrect paper size	Please select the matching paper
X color print head not detected	Black print head not detected Color print head not detected	Please check the black print head and install it correctly Please check the color print head and install it correctly
Abnormal X color print head temperature. Please power off	The black print head protection mechanism has been activated	Cut off the power

	The color print head protection mechanism has been activated	
X color print head not matched. Please contact the customer service	Black print head not matched Color print head not matched	Please contact the customer service
Out of X color ink	Out of black ink Out of cyan ink Out of magenta ink Out of yellow ink	Please replace the ink used up
Front cover opened	The ink cartridge door has been opened	Check the ink cartridge door and close it
X color ink cartridge not installed	Black ink cartridge not installed Color ink cartridge not installed	Please install the ink cartridge correctly
The X color ink cartridge does not match, please replace the ink cartridge	Black ink cartridge not matched	Open the front door, the carriage will automatically return to the replacement position, now replace the ink cartridge
	Color ink cartridge not matched	
Paper jam. After recovering, please press 	Abnormal stop of paper feed motor	First pull out the paper and press the return button to clear the fault code
	Abnormal stop of carriage motor	
Fault # 6121, restart or contact customer service	Encoder strip abnormality	Please power off the printer and restart it. If the error persists after restarting, please contact our customer service
Fault #5200, restart or contact customer service	Wi-Fi module abnormality	
Fault # 6143, restart or contact customer service	Black print head fault	
Fault # 6144, restart or contact customer service	Color print head fault	
Fault # 6139, restart or contact customer service	Short-circuit print head	
Fault #7200, restart or contact customer service	The scanner does not detect the origin	
Fault #7201, restart or contact customer service	Abnormal stop of scan motor	
Fault #7202, restart or contact customer service	Scanner calibration failed	
Fault #7203, restart or contact customer service	Scanner module communication error	
Fault #7204, restart or contact customer service	Scanner system program abnormality	
Check whether the upper cover of the cartridge is properly covered. Press 	Upper cover of the carriage not closed	Open the front cover, close the upper cover of the carriage, and then press the return button to

		clear the fault
--	--	-----------------

Paper jam

Clear the paper jam in the feed tray

1. Gently pull the paper out of the feed tray.

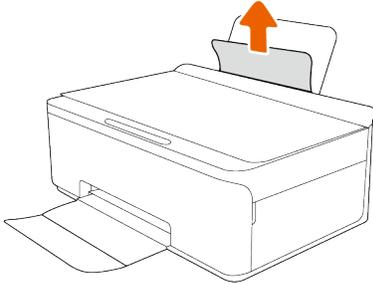

2. Ensure that there are no foreign objects in the paper path, and then feed the paper again.

The paper feed tray baffle can prevent external debris from falling into the paper path and causing severe paper jams.

Clear the paper jam in the exit tray

1. Open the front cover.
2. Gently pull the paper out of the exit tray.

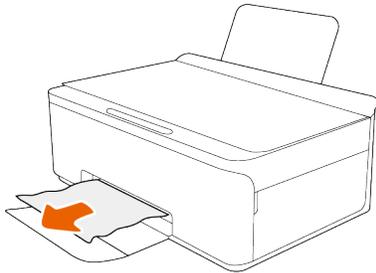

3. Ensure that there are no foreign objects in the paper path, and then feed the paper again.

- ▲ Note: If paper jam occurs with the printer, the printing task will be automatically cancelled. If printing is required, please restart the task.

Understand how to avoid paper jams

- To achieve excellent results, do not overfill the paper feed tray, but ensure that at least 5 pages of paper are loaded.
- When the printer is not in use, please remove the paper and close the paper feed tray to prevent dust and debris from falling into the printer.
- Timely remove the printed paper from the exit tray.
- Ensure that the paper is placed flat in the feed tray and that the edges are not bent or torn.
- Do not place different types and sizes of paper in the feed tray; All paper in the feed tray must have the same size and type.
- Adjust the paper regulator in the feed tray to fit tightly against all paper.
Ensure that the paper regulator does not bend the paper in the feed tray.
- Do not force the print paper into the feed tray.
- Do not add paper while printing.

If the printer is about to run out of paper, wait for the system to display a paper out message before adding paper.

Paper feed problem

Skewed print paper feed

- Load the print paper in the correct direction and use the paper regulator to rest it against the edge of the print paper.

Feed multiple sheets in one time

- If more than one piece of print paper are fed in at the same time, remove all the print paper loaded and then reload again.

Paper shortage error occurred

- If a paper shortage error occurs during the printing process, please load the print paper into the feed tray.

Printing problem

Unable to print from computer

Check the connection (USB)

- Connect the USB cable firmly to the product and the computer.
- If USB cable cannot be recognized, please change to another port or replace the USB cable.
- If the product cannot print when using a USB connection, please try the following measures.
 - Disconnect the USB cable from the computer.
 - Right click on the printer icon displayed on the computer and select Delete Device.
 - Next, connect the USB cable to the computer and try test printing.

Check the connection (network)

- If the access point has been changed, try configuring network settings for the printer again. Connect a computer or smart device to the same SSID as this product.
- Turn off the device to connect to the network. Wait for about 10 minutes, then turn on the device in the following order: access point, computer or smart device, printer. Place the printer and computer or smart device close to the access point, and then try setting up a new network connection.
- Print the configuration report. Check if the network is connected.
- By restoring factory settings, the network settings of the printer can be reset. After restoring factory settings, the user can reconfigure the wireless network.
- Try accessing any website on your computer to ensure that your computer's network settings are correct. If you are unable to access any website, it indicates that there is a problem with your computer. Check the network connection of the computer.

Check the software

- Please ensure that "Deli Inkjet Assistant" and printer driver have been installed.

If "DELI Inkjet Assistant" and Printer driver are not installed, other functions such as printing and scanning cannot be used. Therefore, first install "DELI Inkjet Assistant" and Printer driver. For details, please refer to ["How to download and install "DELI Inkjet Assistant" and Printer driver"](#).

Check the status of the product (Windows)

Click the print task list on the Home screen of "DELI Inkjet Assistant" to check the print tasks.

- Carefully check the print task list for any pending print tasks.
To ensure the success of the print task, you can cancel all documents in the print task list and then restart the print task.
- Ensure that the printer is not offline or in suspension.
If the printer is offline or in suspension, please clear the offline or suspend settings from the printer menu.
- Make sure to set this printer as the Default Printer from the printer menu.
If this printer has not been selected as the default printer, please set it as the Default Printer.
Operation panel ->View devices and printers (printers, printers and faxes) ->Right click on Printers -> Select to set as Default Printer.

Printing speed too slow

- Close all unnecessary applications.
- Reduce print quality. High quality printing will slow down the printing speed.

During continuous printing or copying, the printing speed slows down

- During continuous printing or copying, the printing speed slows down, which is for protecting the print head

Printing image quality problems

▲ Note:

To avoid print quality problems, always turn off the printer with the  "power button", wait for the  "power indicator" to turn off before unplugging or turning off the power socket.

This allows the printer to move the print head to the print head maintenance position on the right, otherwise the print head will dry out and become unusable.

- To improve print quality, refer to the ["Calibrate the print head"](#) and ["Clean the print head"](#) sections.

Light printing color

Problem manifestation: The text color printed by the inkjet printer is not showy enough, not black enough, and the color is light.

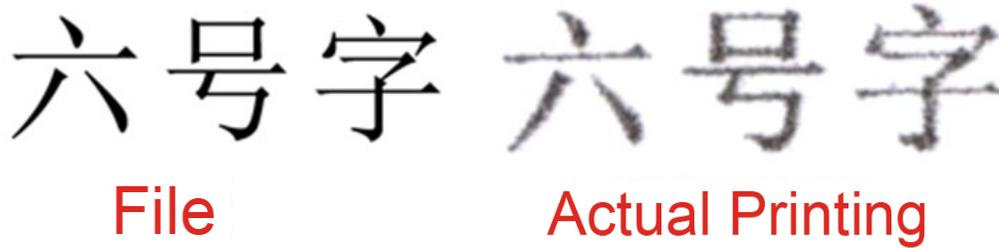

Causes: The original document is displayed in black on the display, while the laser printer uses black solid toner and the inkjet printer uses black water-based ink, which is lighter than the black color as printed by the laser printer and shown on the screen.

Actions:

It is recommended to set "High" or "Optimal" print quality for printing:

- Switch to High in the Print Settings - Print Quality list of the Deli Printing APP.
- On the Deli printer client of the PC side, select to enter Printer Preferences, and set the print quality to Optimal in the extended function menu of the preferences editing interface.

Photo paper is placed reversely, and causes blurred printing colors.

Problem manifestation: Unable to color during printing, resulting in ink loss

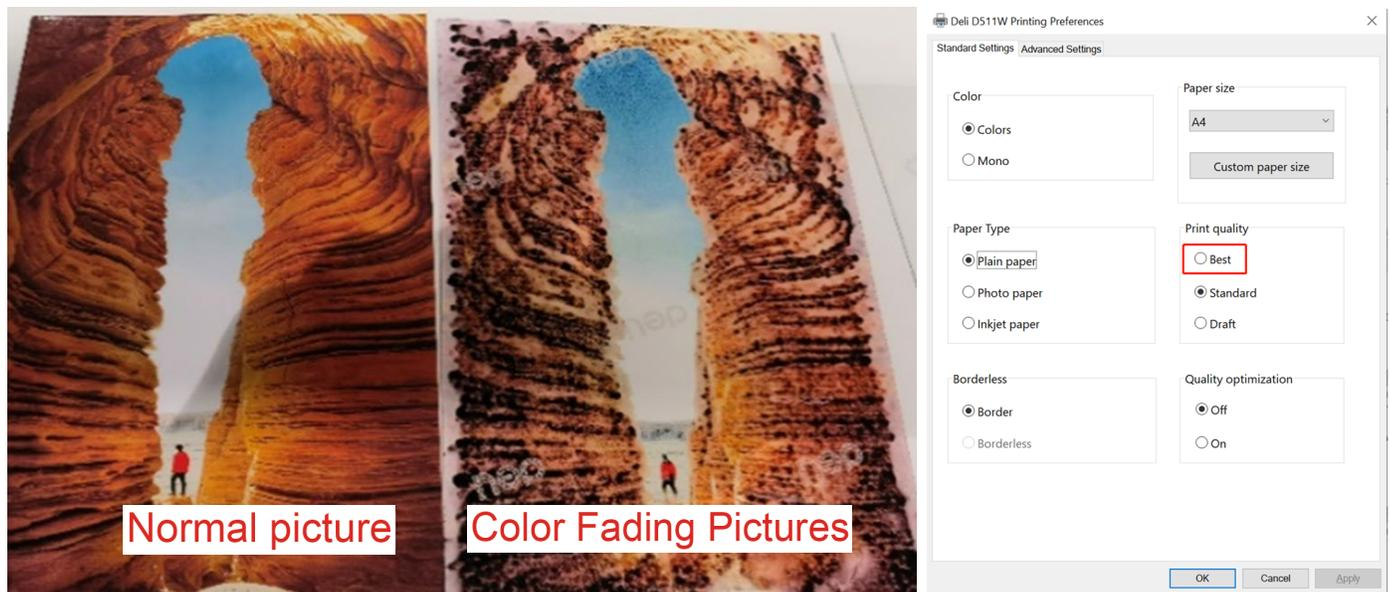

Causes: No photo paper selected for printing options, incorrect placement of the front and back sides of the paper, incorrect selection of photo paper category, etc.

Actions:

- Make sure that the "photo paper" is suitable for color inkjet printers and compatible with dye inks (do not use photo paper with a thermal sublimation). For the type of photo paper, it is recommended to use 250g and above matte RC photo paper.
- Use the front (printed side) of the photo paper for printing. For details, refer to the photo paper package or instructions, for

example:

- a) Generally, the brand logo will be printed on the back of the photo paper to distinguish it from the front.
- b) If there is no brand logo, the smooth surface is usually the printed surface; or by using two fingers to pinch the photo paper and releasing it after a few seconds, the side sticking to the hand is usually the front side of the photo paper. (Because the front has the ink receptive coating layer, it is more sticky.)

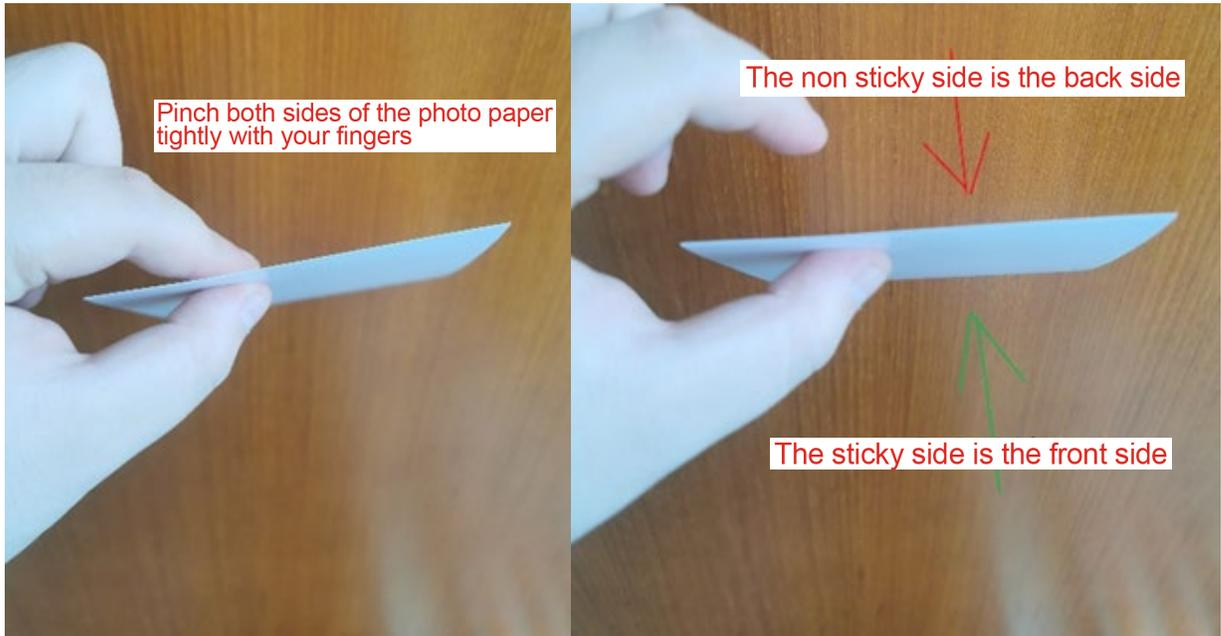

3. The photo paper is properly placed in the paper box; Make sure that the front of the photo paper is facing outwards (or upwards), and the back touches the baffle plate when it is put into the paper box. At the same time, adjust the blue plate in the paper box to clamp the photo paper correctly.

Scan problem

Unable to start scanning

- Connect the USB cable firmly to the product and the computer.
- If USB cable cannot be recognized, please change to another port or replace the USB cable.

Scanning speed too slow

- Can reduce the resolution. High resolution will slow down the scanning speed.

Resolve the problem of inability to use Web services

If problems are met in using Web services, please check the following items:

- Ensure that your printer is connected to the LAN.
- Please ensure that the device is connected to the LAN.
- Ensure that the network hub, switch, or router has been turned on and working properly.
- If the printer is connected wirelessly, ensure that the wireless network is functioning properly.

Restore factory settings

If the printer's functionality or network settings have been changed, you can restore the printer to its factory settings. You can also reset the network by restoring factory settings to troubleshoot network connectivity problems.

Restore factory settings (host)

Select Menu -> **6 Settings-Restore factory settings**, operate as prompted on the screen.

Firmware upgrade

The printer supports multiple ways to upgrade firmware. Please upgrade according to the type of device connected.

Firmware upgrade with "DELI Inkjet Assistant"

Before firmware upgrade from your computer, please ensure that 'Deli Inkjet Assistant' application driver has been installed.

The printer and computer must be connected and turned on.

1. Open "DELI Inkjet Assistant" on your device.
2. Click on the Maintenance Functions tab.
3. Click on the Printer System Update.
4. Click on Detect Version. When the device detects a new firmware version, please download and upgrade.

Encoder strip contamination

Dip a clean tissue/dust-free cloth in an appropriate amount of alcohol/pure water, gently wipe the encoder strip in front of the belt shown in the figure three times back and forth, and then gently wipe the encoder strip three times back and forth with a dry tissue/dust-free cloth.

Do not touch the metal rod below the encoder strip when wiping.

After confirming with the light that there is no obvious dirt on the encoder strip, close the front door, plug in the power cord, and turn on the machine to observe if it returns to normal.

Appendix

Material Safety Data Sheet (MSDS)

To obtain the Material Safety data sheet (MSDS) for consumables containing chemicals (such as print head), please visit the following website: www.deliprinter.com

Product specifications

Interface and network	USB port	Hi-speed USB2.0
	Wireless network	Network type: 802.11b/g/n; Bandwidth: 2.4GHz Supporting Wi-Fi Direct
Operation system	Windows	Note: The recommended Windows system for users is as follows: Windows 11 (64 bit), Windows 10 (64 bit/32 bit) Windows 8.1 (64 bit/32 bit), Windows 7 (64 bit/32 bit)
Print	Printing technology	Thermal jet type
	Printing language	GDI
Copy	General copying	Supporting black & white/color, up to 99 copies
	ID card copying	Only supporting black & white, up to 99 copies
Scan	Scanner type	Tablet
	Scanning method	CIS contact image sensor
	Scanning resolution	Hardware: up to 1200x1200dpi; Optics: up to 1200dpi
	Scanning color depth	Up to 24 bit color depth
	Gray scale	256 grayscale
Environment specifications	Working temperature range	5~35°C
	Working humidity range	10%~80%
	Working temperature range recommended	16~32°C
	Working humidity range recommended	20% ~ 80%
	Storage & transportation temperature range	-25 ~ 40°C
	Non-working humidity range	10% ~ 93%
	Service altitude	Below 2000 m
Power specifications	Power source	Built-in power supply
	Rated voltage	AC 220-240V
	Rated power	50/60 Hz
	Power consumption	As per GB 21521-2014

Copy restrictions

Copying the following documents may be illegal.

This list is incomplete. For any questions, please consult the legal representative of your jurisdiction.

- Banknotes
- Money order
- Deposit slip
- Postage stamps (stamped or unstamped)
- Identity card or logo
- Identification badge or seals
- Compulsory military service or conscription documents
- Cheques or bills of exchange issued by government agencies
- Motor vehicle driver's license and ownership certificate
- Traveler's check
- Food stamp
- Passport
- Immigration documents
- Domestic tax revenue stamp (stamped or unstamped)
- Bonds or other debt certificates
- Share certificate
- Copyright or artwork without owner's permission